

# COVID-19-Induced Hoarding Intention Among the Educated Segment in Indonesia

*by* Jhanghiz Syahrivar

---

**Submission date:** 27-May-2021 12:49AM (UTC+0700)

**Submission ID:** 1594724775

**File name:** Covid-19-Induced\_Hoarding\_Intention\_Q1.pdf (1M)

**Word count:** 8311

**Character count:** 44982

# COVID-19-Induced Hoarding Intention Among the Educated Segment in Indonesia

SAGE Open  
April-June 2021: 1–13  
© The Author(s) 2021  
DOI: 10.1177/21582440211016904  
journals.sagepub.com/home/sgo  

Jhanghiz Syahrivar<sup>1,2</sup> , Genoveva Genoveva<sup>2</sup>, Chairy Chairy<sup>2</sup>, and Siska Purnama Manurung<sup>2,3</sup>

## Abstract

The media commonly reports panic buying amid the COVID-19 pandemic. Panic buying occurs when people engage in hoarding of basic needs as well as protective materials, which drives scarcity and price increases. There are four variables integrated in this study which are COVID-19-induced hoarding intention, COVID-19-related attitude, COVID-19-related knowledge, and health locus of control. This study gathered 265 university professors from 25 prominent public and private universities in Indonesia. To our best knowledge, this is the first study that discusses hoarding intention during the pandemic among the educated segment. Structural Equation Modeling (SEM analysis) via AMOS software was employed to test the hypotheses. This study reveals that (a) a better knowledge about the COVID-19 pandemic increases vigilance toward the COVID-19 pandemic and (b) a higher external health locus of control increases the COVID-19-induced hoarding intention. The theoretical contributions as well as managerial implications of this study, especially to policy makers, are provided.

## Keywords

hoarding intention, attitude, knowledge, health locus of control, panic buying, COVID-19

## Introduction

COVID-19 outbreak initially occurred in Wuhan, China, presumably since late December 2019 (Jiang et al., 2020). A prediction model by De Salazar et al. (2020) which incorporates cross-countries' air travel volumes and numbers of COVID-19 imported cases suggests that Indonesia should have reported at least five cases by February 2020. On 2 March 2020, the Government of Indonesia broke the silence and reported the first two cases of COVID-19 in the country (Yulisman, 2020). Amid the rapid increase of cases of COVID-19 in the country, stockpiling—"panic buying" as often described by the mass media—occurred, particularly in Jakarta where the virus hit the hardest (Rayda, 2020). Van Bavel et al. (2020) argue that local news which abuse the word "panic buying" often foster the very phenomena itself by making people think that others are doing it hence it is also right to do the same.

Panic buying generally occurs when consumers anticipate increasing demand and shortage of supplies thereby they would rush to nearby stores to hoard basic needs (Tsao et al., 2019; Zheng et al., 2021). Previous studies suggest that panic buying is rational and adaptive (Kirk & Rifkin, 2020; Kulemeka, 2010; Van Bavel et al., 2020). Therefore, we attempt to follow up this notion by investigating the hoarding intention of the educated segment during the pandemic. To

be precise, our study involved exclusive samples of university professors in Indonesia. Second, we wished to investigate the antecedents of hoarding intention, labeled as COVID-19-induced hoarding intention or CIHI. From the previous studies dealing with infectious diseases, we found some relevant antecedents, namely, attitude, knowledge, and health locus of control (HLOC; Abdollahi et al., 2019; Albarrak et al., 2021; Garbe et al., 2020; Kirk & Rifkin, 2020; Rajkumar, 2020; Szymkowiak et al., 2020).

The rest of this article is organized as follows: The section following the introduction section is the "Literature Review" section that includes the core theories of this study. The "Research Methodology" section includes the steps we took to gather and analyze the data. The "Findings" section includes statistical results. The "Discussion" section includes theoretical contributions and managerial implications as well as future research directions. The last section is the conclusion section that includes the summary of this study.

<sup>1</sup>Corvinus University of Budapest, Hungary

<sup>2</sup>President University, Bekasi, Indonesia

<sup>3</sup>University of Malaya, Kuala Lumpur, Malaysia

## Corresponding Author:

Jhanghiz Syahrivar, Institute of Marketing, Corvinus University of Budapest, Fővám tér 8, 1093 Budapest, Hungary.  
Email: jhanghiz@president.ac



## Literature Review

CIHI Panic generally occurs as a response to social crises, such as disasters and riots, and manifests at different levels in individuals and organizations (Quarantelli, 1993). Excessive fear and panic behavior can manifest as hoarding and stockpiling of basic needs or particular items (Rajkumar, 2020). Panic buying may occur as a consequence of supply disruption risk in the market (Tsao et al., 2019; Zheng et al., 2021). Consumers would rush to the nearby stores to hoard basic needs in large quantities or more than the usual in anticipation of shortages in the near future. According to Kirk and Rifkin (2020), hoarding is an act of safeguarding a large quantity of essential goods for future use due to the fear of their scarcity and loss of control.

Previous studies suggest that pre-disaster shopping activities in anticipation of shortage or potential self-isolation—often painted as “panic buying”—is rational and adaptive (Kirk & Rifkin, 2020; Kulemeka, 2010; Van Bavel et al., 2020). According to Zheng et al. (2021), rational consumers may join in the panic buying frenzy as a consequence of social learning. During disasters or outbreaks, consumers’ knowledge about their present circumstances are constantly updated by external sources and so are their beliefs about the risks they are facing. Moreover, according to Chan et al. (2013), anticipatory purchase occurs when customers are unable to use a product by the time they purchase it but such purchase reflects the desire to consume in the future, albeit uncertain one. For instance, the purchase of a large amount of medical masks when customers anticipate that they will have to wear it daily in the future when the outbreak is worsening.

People react differently during social crises or what seem to be panic situations (Quarantelli, 1993). Their responses during the COVID-19 pandemic depend on multiple factors, such as their psychological well-being (Arafat et al., 2020) and personality traits (Bacon & Corr, 2020). For instance, a study by Zettler et al. (2020) suggests that people with a higher emphasis on self-interests (a higher level in the dark factor of personality) are less willing to follow health recommendations during the COVID-19 pandemic. Similarly, a study by Triberti et al. (2021) suggests that the traits of the Dark Triad (e.g., narcissism, Machiavellianism, and psychopathy) are negatively linked with the adoption of healthy habits. In essence, these traits are predictors of antisocial behavior (Jones et al., 2017; van Geel et al., 2017). People with antisocial behavior will prioritize their goals or interests over others’ well-being during difficult times. Antisocial behavior during disasters can manifest in hoarding of products considered necessary to one’s survival, such as foods, medicines, clothes, and also guns (Cukier & Eagen, 2018; Van Bavel et al., 2020).

Hoarding also occurs amid the COVID-19 pandemic. For instance, a study by Garbe et al. (2020) across 22 countries suggests that people who feel more threatened by the

COVID-19 pandemic have the propensity to hoard toilet paper. Kirk and Rifkin (2020) argue that hoarding cleaning products is more unique to a pandemic. However, an experimental study by Columbus (2020) with U.K. samples suggests that when people realize that their personal gain comes at the expense of others, they may refrain from hoarding. Finally, a study by Pantano et al. (2020) highlights panic buying amid the COVID-19 pandemic, resulting in scarcity as well as price increases of basic needs in the affected countries.

In this study, CIHI is defined as the propensity to increase purchases of basic goods in response to the COVID-19 pandemic. CIHI also manifests as antisocial, such as the intention to hoard or stockpile basic needs without much regard to the needs as well as the safety of others. Moreover, CIHI reflects the intention to protect the self from supply shortage risks in the near future following a pandemic.

### COVID-19-Related Knowledge (CKNW)

Knowledge is classified into three types, namely, subjective knowledge, objective knowledge, and knowledge based on one’s previous experiences (Brucks, 1985). Subjective knowledge refers to how much individuals think they know about certain issues or topics (e.g., COVID-19); meanwhile, objective knowledge includes factual information stored in one’s memory which is greatly influenced by the variety and the credibility of the sources (Lin et al., 2021; Tassiello & Tillotson, 2020; Wirz et al., 2020). For instance, sources of knowledge about COVID-19 may come from government officials, doctors, news, social media, and scientific journals. Different sources will affect one’s objective knowledge. Finally, one’s previous experiences with other infectious diseases (e.g., SARS, MERS) will also contribute to one’s knowledge (S. Lee, Hwang, & Moon, 2020; Temsah et al., 2020). In this context, CKNW is the degree to which a person is knowledgeable about some facts concerning the COVID-19 pandemic, such as its origin, symptoms, ways of transmissions and preventive actions against the virus.

### COVID-19-Related Attitude (CATD)

Attitude is an affective and evaluative response toward an object which stems from one’s weighted sums of beliefs (Wilkie & Weinreich, 1972). Attitude may involve one’s perception of risk concerning an external threat in his or her immediate environment (Rimal & Real, 2003; Van Bavel et al., 2020). In this regard, CATD refers to one’s beliefs toward the potential danger of the COVID-19 pandemic as reflected by their heightened risk perceptions as well as vigilance toward the virus and what they believe should be done about it.

According to the Knowledge Attitude and Practice model, if people are more knowledgeable about an issue, it would change their attitude about the issue and eventually their

practice. Previous studies on infectious diseases (e.g., MERS) have indicated a positive relationship between knowledge and attitude (Abdollahi et al., 2019; Albarrak et al., 2021), which means the higher the knowledge about an infectious disease, the more positive the attitude of the health care workers or patients. It is to be understood in this context that a positive attitude means that people are high in risk perception associated with the COVID-19 pandemic hence are more vigilant toward it. Moreover, in the context of H1N1, a prolonged exposure to news and social media platforms (e.g., twitter, Facebook)—thereby having more knowledge or information—could increase the risk perception attitude toward the virus (Lin et al., 2021). Therefore, the first hypothesis was formulated as follows:

**Hypothesis 1 (H1):** A better knowledge about the COVID-19 pandemic increases vigilance toward the COVID-19 pandemic.

### HLOC

HLOC in the social learning theory consists of (a) the expectation that certain things will occur because of the behavior that they do, (b) the values adopted by an individual concerning his or her behavior, and (c) psychological condition of an individual which is affected by his or her situation or circumstance (Norman et al., 1998; Rotter, 1982).

In Wallston et al. (1978), HLOC has three dimensions: internal, powerful others, and chance. Powerful others and chance are closely related to the external locus of control (LOC). In this study, we incorporated and adapted only one dimension of HLOC dealing with God, chance or luck (external factors). This dimension is of our particular interest due to the fact that Indonesians are considered high in religiosity (Poushter & Fetterolf, 2019). Previous studies suggest that their consumption activities cannot be separated from their religious or spiritual convictions as well as environmental concerns (Chairy & Syahrivar, 2020; Genoveva & Syahrivar, 2020). Therefore, we assumed that the belief in external (supernatural) power was also quite high among our respondents.

According to Wilski et al. (2020), people with high internal HLOC have a more optimistic attitude toward life and a reduced perception of disease severity hence they expect to carry their activities as usual even though they are physically unfit. People with high internal LOC are also associated with improved health habits (Brown et al., 2017). Meanwhile, previous studies reported that people with high external LOC had low compliance with the control or the management of the disease as well as low well-being due to depression or anxiety (Bellini et al., 2011; Brown et al., 2017; Schreitmüller & Loerbroks, 2020). Moreover, people with high external LOC are able to dissociate themselves from their illness due to the belief that it is a fate or the responsibility of a powerful other, including their doctor or medical caretaker (Brown

et al., 2017). In this study, we assumed that people with high external HLOC would be less vigilant toward the COVID-19 pandemic, hence the second hypothesis was formulated as follows:

**Hypothesis 2 (H2):** A higher external HLOC decreases vigilance toward the COVID-19 pandemic.

Previous studies suggest that risk perception attitude improves the intention to protect the self against the threats in one's immediate environment (Rimal & Real, 2003; Van Bavel et al., 2020). A study by Szymkowiak et al. (2020) on in-store buying behavior during the COVID-19 pandemic suggests that stockpiling is influenced by one's attitude, particularly on the severity of the virus transmission and the risk of being infected while doing the shopping activities. Therefore, hoarding or stockpiling is essentially an attempt to reduce the numbers of going out for shopping during the pandemic. A study by Van Bavel et al. (2020) suggests that when individuals' risk perceptions are high, they are psychologically compelled to hoard protective materials (e.g., sanitizers, medical masks). According to Dubey et al. (2020), when the public are so concerned and worried about scarcity of essential goods due to lock-down, this feeling or belief can motivate hoarding of daily essentials or resources, such as non-easily perishable foods and medicines. Moreover, the belief in buying and piling up basic needs will give rise to the feeling that one is in full control of his or her destiny (Frost et al., 1995; Frost & Steketee, 1998; Kirk & Rifkin, 2020). Therefore, the third hypothesis was formulated as follows:

**Hypothesis 3 (H3):** A higher vigilance toward the COVID-19 pandemic increases the CIHI.

Knowledge plays a significant role in individuals' responses during the COVID-19 pandemic. Abrams and Greenhawt (2020) argued that poor risk communication coupled with heightened risk perception during the COVID-19 pandemic lead to hoarding of personal protective equipment. A study by Jovančević and Miličević (2020) demonstrates that people who were prone to conspiracy theories (suggesting poor knowledge) were also prone to hoarding. The belief in misinformation was associated with poorer COVID-19 knowledge and preventive actions (J. J. Lee, Kang, et al., 2020). People's propensity toward hoarding or stockpiling of basic needs may be induced by rumors and disinformation from social media (Naeem, 2020). In contrast, a study by Clements (2020) on the relationship between the CKNW and behavior among the Americans demonstrated that a better COVID-19 knowledge had a negative relationship with hoarding or buying more goods than usual during the pandemic. Moreover, Kim et al. (2020) demonstrated that precise information about the COVID-19 and comparative statistics (e.g., U.S. COVID-19 cases vs. U.S. Flu 2019 Cases) reduced perceived threats and stockpiling intention. In this study, we

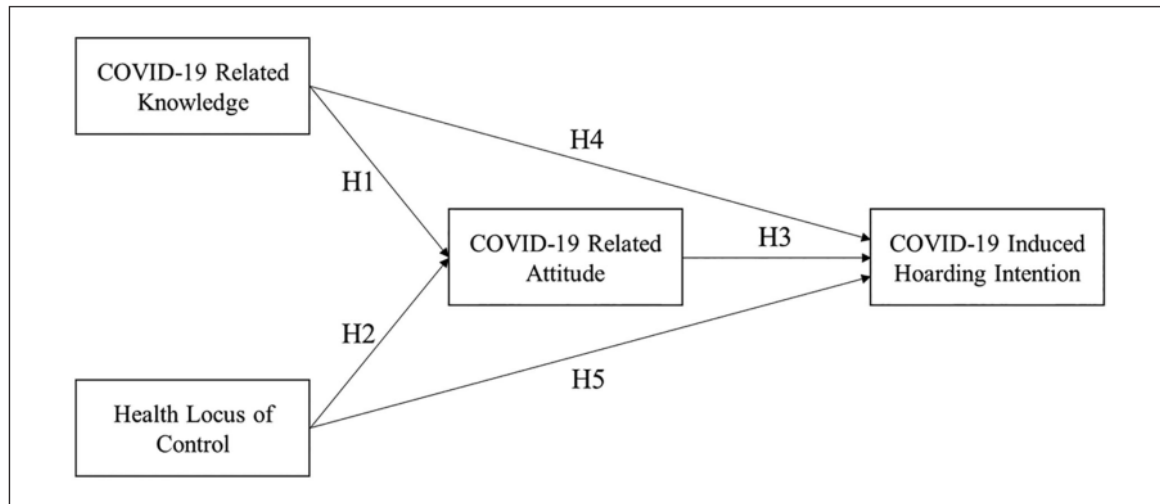

**Figure 1.** Theoretical framework.

argued that a better knowledge (e.g., scientific facts, expert opinion) was the basis for reasonable and responsible actions; hence, as the public gained more accurate information on the COVID-19 pandemic, they might refrain from making poor decisions that jeopardized the well-being of others, such as hoarding or stockpiling of basic needs. Therefore, the fourth hypothesis was formulated as follow:

**Hypothesis 4 (H4):** A better knowledge about the COVID-19 pandemic decreases the CIHI.

Panic buying as manifested in hoarding or stockpiling of basic needs occurs as a mechanism by which consumers attempt to derive control, especially during a disaster or an outbreak (Frost & Steketee, 1998; Kirk & Rifkin, 2020). Consumers may feel more in control during difficult situations when they have abundant access to basic needs. The more they hoard or stockpile the basic needs, the more they feel in control. In this regard, they feel the need to be proactive to ensure their well-being. A study by Frost et al. (1995) reports a positive and significant correlation between hoarding and external LOC. People with high external LOC believe that their actions are heavily influenced by external factors, such as God, chance, or luck, hence they have less personal control over their lives. According to Rucker and Galinsky (2008), people had a strong desire to acquire or possess certain objects to compensate for their powerlessness. In this study, we assumed that people with high external HLOC would attempt to derive more control over their lives through hoarding of basic needs. Therefore, the fifth hypothesis was formulated as follows:

**Hypothesis 5 (H5):** A higher external HLOC increases the CIHI.

## 5

### Research Methodology

Figure 1 illustrates the theoretical framework of this study. In total, there are two exogenous variables (CKNW and HLOC), one mediating variable (CATD), and one endogenous variable (CIHI). This study has five hypotheses.

The nature of this study is quantitative, emphasizing on descriptive analysis. We employed purposive sampling in this study by targeting professors from 25 prominent universities in Indonesia. We distributed a 5-point Likert-type scale of self-reported online questionnaires which consists of 27 items. Two filter questions were introduced: (a) Are you fully aware of the COVID-19 pandemic in Indonesia? (b) Are you a professor/lecturer in Indonesia? To which, to be qualified, respondents had to answer “YES” to both questions. Out of 285 respondents, a total of 265 respondents were deemed valid for this study (please see the appendix).

COVID-19-Induced Hoarding Intention (CIHI) scale (five items) was adapted from Sheu and Kuo (2020) and Quarantelli (1993); the COVID-19-Related Attitude (CATD) Scale (nine items) was adapted from Elrggal et al. (2018) and Abdollahi et al. (2019); the COVID-19-Related Knowledge (CKNW) scale (seven items) was adapted from Bhagavathula et al. (2020); finally, Health Locus of Control (HLOC) scale (six items) was adapted from Wallston et al. (1978).

We conducted a pre-test involving 68 respondents to check the reliability of our measurements. The Cronbach’s alphas of the original scales range from .570 to .838. After we affirmed their reliability, we disseminated an online questionnaire to potential respondents (university professors). From the 265 valid cases, we employed factor analysis to test whether the items belonged to the constructs they intended to measure. In this phase, we also checked Kaiser–Meyer–Olkin (KMO),

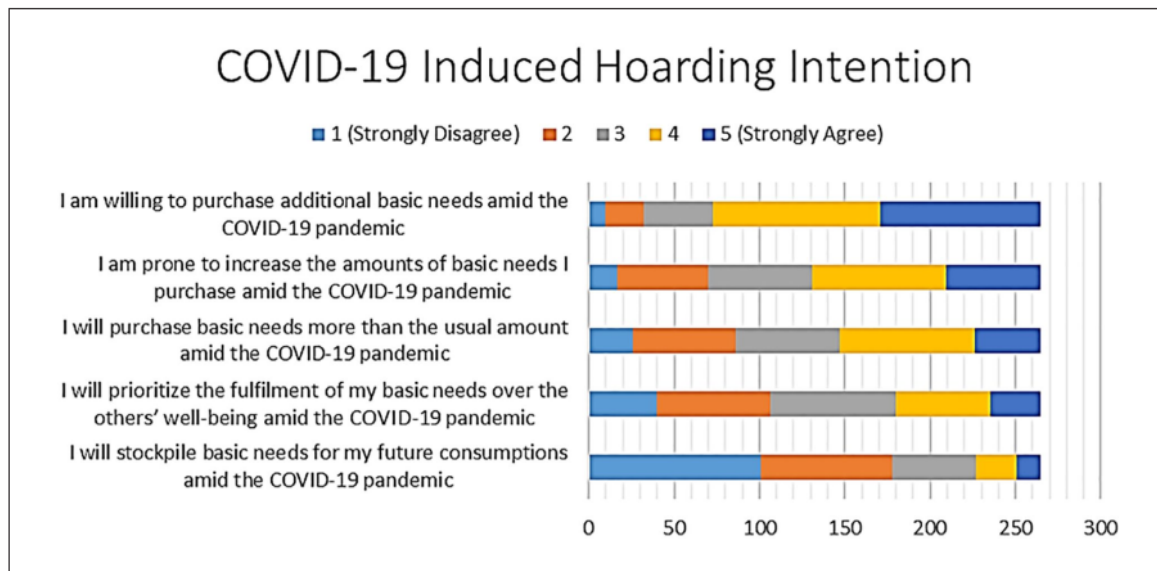

**Figure 2.** COVID-19-induced hoarding intention.

eigenvalues, cumulative variance, factor loadings, and Average Variance Extracted (AVE). To test the hypotheses and the fitness of the model presented in this study, we employed Structural Equation Modeling (SEM) through AMOS software. In this phase, we checked the root mean square error of approximation (RMSEA), standardized root mean square residual (SRMR), goodness of fit index (GFI), adjusted goodness of fit index (AGFI), normed fit index (NFI), Tucker–Lewis index (TLI), and comparative fit index (CFI). Guidelines from Schreiber et al. (2006) and Hair et al. (2006) were used in this study.

## Findings

### Descriptive Analysis

From Figure 2, we can see that the intention to hoard among the educated segment (Items 1, 2, and 3) are moderate to high (frequencies of Likert-type scores from 3 *maybe* to 5 *strongly agree*). For instance, the item “I am willing to purchase additional basic needs amid the pandemic” (a proxy of hoarding behavior) indicates about 75% of the responses indicate agreements (agree and strongly agree). However, when the items clearly reflect antisocial intention, such as “I will prioritize the fulfillment of my basic needs over the others’ well-being amid the pandemic,” more responses tend to reflect their disagreement (frequencies of Likert-type scores from 2 *disagree* to 1 *strongly disagree*). The last item about “stockpile/stockpiling” mostly reflects their disagreement. We could only assume that the word “stockpile” had a negative connotation to our respondents. Also

throughout answering this section, the university professors might realize that by answering 4 and 5, it was not socially acceptable for “educators.”

Figure 3 presents the frequency of each indicator in the CATD. At glance, the Indonesian respondents demonstrated a higher vigilance toward the COVID-19 pandemic—a reflection of their attitudes as well as societal buy-in. Societal buy-in is pivotal during the pandemic where people should commit to social distancing. If people are more lenient toward the impending danger, local governments will face challenges in containing the spread of infectious diseases (Newbold et al., 2014). Two interesting indicators in this variable are “I will not go to a hospital where COVID-19 patients are treated” and “I will not go to a hospital without a clear COVID-19 infection control isolation policy.” The perceptions that hospitals are possible hotspots for virus transmission will become inhibitors to mass testing. Out of fear of getting infected at the hospitals, they may delay going to the hospitals until their conditions become worse with time. If more patients only visit the hospitals for treatments when they are already in a critical state, eventually the health care system will be overloaded thereby not enough health care workers and facilities to save lives.

Figure 4 presents the frequency of each indicator in the CKNW. The results indicate that CKNW of the Indonesian respondents were varied. For instance, the first indicator “COVID-19 is thought to have originated from bats” and the second indicator “COVID-19 is transmitted through air, contact, fecal-oral routes” have higher standard deviation (*SD*) compared with other indicators. High *SD* means that values (responses) are more spread and farther from

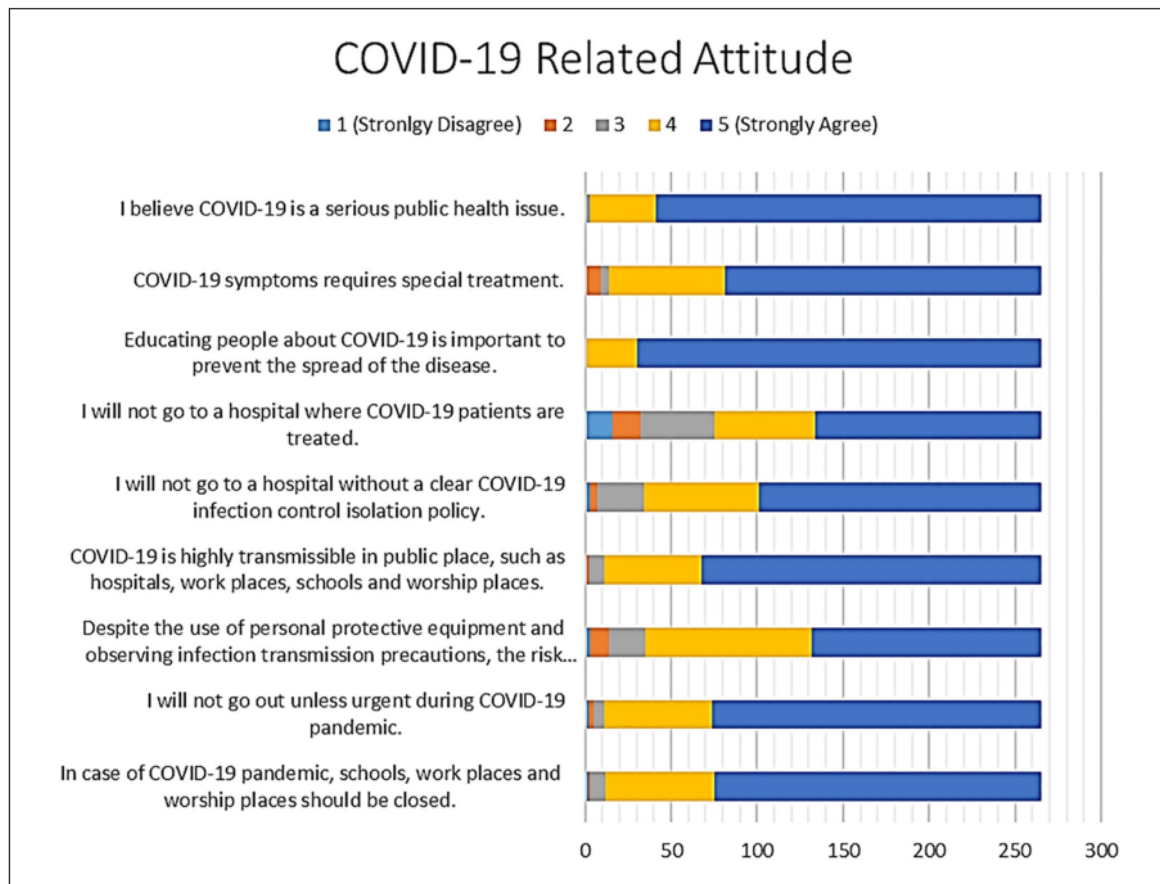

**Figure 3.** COVID-19-related attitude.

the means. This is understandable owing to the fact that amid the pandemic, the respondents were also exposed to various disinformation and inaccurate news either from the mainstream media or the non-mainstream one. To be certain, we contacted some of our respondents randomly to clarify their standpoints on the first indicator and we found that the respondents were not certain on the origin of the COVID-19. Some believed that the virus was engineered (e.g., a bio-weapon) suggesting that the respondents were not immune to conspiracy theories. Indeed, a cross-cultural study by Jovančević and Miličević (2020) also highlighted the role of conspiracy theories in the COVID-19-related behavior, such as hoarding. The responses toward the rest of the indicators were more inclined toward agreement (4 and 5 Likert-type points).

Figure 5 presents the frequency of each indicator in HLOC. The results indicate that the respondents were more inclined toward external HLOC in a sense that they believed that some aspects of their health were beyond their personal control. As Indonesians in general are considered high in

religious commitment (Poushter & Fetterolf, 2019; Syahrivar & Pratiwi, 2018), items where the word “God” was ascribed, such as “My good health is largely a matter of good fortune or God’s blessing” and “Luck or God plays a big part in determining how soon I will recover from an illness” have higher agreements among the respondents.

### Factor Analysis

Next, we conducted the exploratory factor analysis (EFA) to see if the items included in this study belong to the constructs they intend to measure. Based on Table 1, KMO suggests a value of 0.746. According to Kaiser (1970), the minimum value of the KMO should be 0.50 considered suitable for factor analysis.

Table 2 suggests that four factors are the optimum solution in which the total eigenvalue is 1.725 and the cumulative variance is 61.7%. According to Hair et al. (2006), a factor solution must account for 60% or more of total variance and eigenvalues greater than 1.

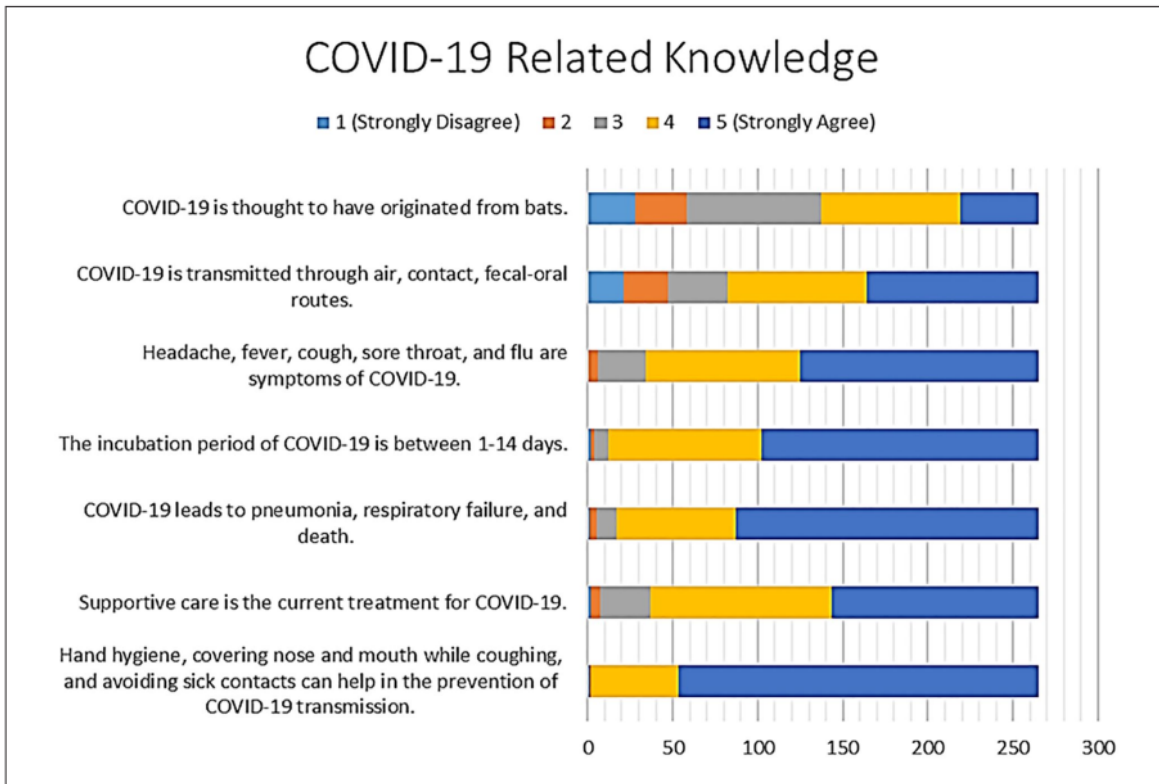

Figure 4. COVID-19-related knowledge.

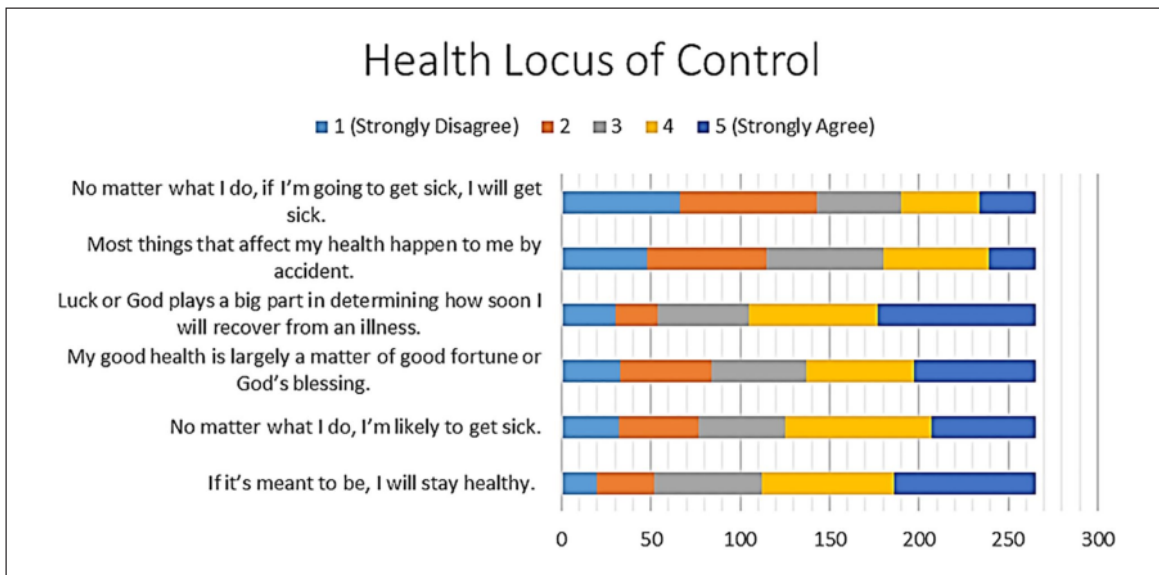

Figure 5. Health locus of control.



14

**Table 1.** KMO and Bartlett's Test.

KMO measure of sampling adequacy	.746
Bartlett's test of sphericity	
Approximate $\chi^2$	1,291.994
df	105
Sig.	.000

Note. KMO = Kaiser–Meyer–Olkin.

Items with communalities less than 0.5 were deleted during the process (CKNW1, CKNW2, HLOC2, HLOC5, CATD2, CATD4, CATD7 and CIHI1). The rotated solution with varimax method can be seen in Table 3. For convergent validity, the factor loadings of all items should exceed 0.50 (Hair et al., 2006).

The communalities of all items exceeded 0.5. The Cronbach's alpha of CKNW, HLOC, CATD, and CIHI were .618, .717, .738, and .829 consecutively. Meanwhile, the AVE for CKNW, HLOC, CATD, and CIHI were 0.48, 0.63, 0.49, and 0.66 consecutively. Unfortunately, some items in the original scales of respective variables had to be eliminated during the EFA process, including item CIHI1. The EFA results suggest a one-dimensional factor solution for CIHI.

## SEM

In the confirmatory factor analysis (CFA) stage, we had to eliminate CIHI5 to improve the fitness of our proposed model. The final SEM output is presented in Figure 6.

Table 4 compares the values of the indicators of model fit against the thresholds recommended by Schreiber et al. (2006).

Table 5 presents the regression weights of the SEM model. The results suggest that we can support the relationship between CKNW and CATD (H1) and HLOC and CIHI (H5); meanwhile, the relationships between HLOC and CATD (H2), CATD and CIHI (H3), and CKNW and CIHI (H4) cannot be supported in this study.

## Discussion

Our study empirically proves that a better knowledge about the COVID-19 pandemic increases vigilance toward the COVID-19 pandemic (H1). As the knowledge about COVID-19 is improved, people's risk perception increases and they become more vigilant. This result is in line with the previous studies by Abdollahi et al. (2019) and Albarak et al. (2021) in the context of MERS.

Our study empirically proves that a higher external HLOC increases the CIHI (H5). People who believe that their health are heavily influenced by external factors (e.g., God, luck, and chance) tend to engage in hoarding and stockpiling during the pandemic as a mechanism to derive

personal control (Frost et al., 1995; Frost & Steketee, 1998; Kirk & Rifkin, 2020). This is in line with the compensatory consumption theory that suggests that people attempt to compensate for their powerlessness or lack of personal control in their lives by acquiring or possessing certain objects (Rucker & Galinsky, 2008).

Our present study cannot prove that a higher external HLOC decreases vigilance toward the COVID-19 pandemic (H2). The lack of evidence could be the result of poor HLOC scale that failed to capture or describe external LOC more accurately. Indonesians were considered high in religiosity (Poushter & Fetterolf, 2019; Syahrivar & Pratiwi, 2018); hence, the issue might arise from the confusion between "luck" and "God" as the external forces perceived to affect one's life. Future studies may refine the HLOC scale.

Our present study cannot prove that a higher vigilance toward the COVID-19 pandemic increases the CIHI (H3). Because our samples were university professors, some might incline to come up with socially desirable responses (Grimm, 2010). For instance, Item 5 on the CIHI scale used the word "stockpile" which was the least admitted by the respondents. In contrast, Items 1, 2, and 3 on the CIHI scale were also about stockpiling or hoarding yet these items got more decent responses, enough to conclude that our respondents engaged in hoarding to some extent during the pandemic. Moreover, we also need to report that through correlation analysis, various items of CATD have positive correlations with Items 1, 2, and 3 on the CIHI scale. Future studies may refine the CIHI scale to take into account the social desirability bias.

Our present study cannot prove that a better knowledge about the COVID-19 pandemic decreases the CIHI (H4). Previous studies suggest that hoarding of basic needs could be an attempt to reduce the numbers of going out for shopping during the pandemic hence reducing the risk of transmission (Szymkowiak et al., 2020) and to anticipate shortage of basic needs (Chan et al., 2013; Tsao et al., 2019; Zheng et al., 2021). One's previous experiences with other infectious diseases (e.g., SARS and MERS) may also affect the knowledge about the transmission risks and potential shortage of basic needs during the COVID-19 pandemic (S. Lee, Hwang, & Moon, 2020; Temsah et al., 2020). In turn, respondents' previous experiences combined with their new knowledge about the COVID-19 pandemic may hasten or delay their subsequent actions.

From the descriptive analysis, we can conclude that (a) most respondents had a high propensity to engage in one aspect of hoarding behavior amid the pandemic which is the anticipatory purchase but less tendency on the other aspect which is the antisocial intention; (b) the results of CATD among the respondents shows that they were vigilant amid the pandemic; (c) the CKNW among the respondents were relatively high except on few items, such as the origin of the virus; and (d) HLOC among the respondents was leaning toward external LOC.

**Table 2.** Total Variance Explained.

Component	Initial Eigenvalues			Extraction sums of squared loadings			Rotation sums of squared loadings		
	Total	% of Var	Cum%	Total	% of Var	Cum %	Total	% of Var	Cum %
1	3.392	22.615	22.615	3.392	22.615	22.615	2.912	19.411	19.411
2	2.757	18.381	40.996	2.757	18.381	40.996	2.677	17.845	37.256
3	1.888	12.589	53.584	1.888	12.589	53.584	1.944	12.958	50.214
4	1.219	8.129	61.714	1.219	8.129	61.714	1.725	11.500	61.714

**Table 3.** Rotated Component Matrix (Varimax).

Items	Component			
	1	2	3	4
CKNW3				.781
CKNW4				.698
CKNW5				.609
HLOC1			.721	
HLOC3			.810	
HLOC4			.848	
CATD1	.758			
CATD3	.757			
CATD5	.606			
CATD6	.633			
CATD8	.744			
CIHI2		.864		
CIHI3		.868		
CIHI4		.749		
CIHI5		.759		

We can think of three theoretical contributions of this study: First, this study operationalized panic buying which was mostly discussed in qualitative studies and proposed a new measurement called COVID-19-Induced Hoarding Intention. Second, we gathered university professors as the samples, and the results of our study suggest that educated people also engaged in hoarding of basic needs during the pandemic. We argued that panic buying could be rationally driven, such as in the context of anticipatory purchase whereby people constantly update their knowledge about disasters and anticipate future shortage of basic needs (Chan et al., 2013). Third, our study provides the weight of evidence on the relationship between knowledge and attitude in the context of pandemic. Finally, our study confirms the positive and significant effect of external HLOC on hoarding or stockpiling. Previous study by Frost et al. (1995) only confirmed the correlations between the two.

Managerial implications of this study to policy makers (e.g., local governments) and retailers in Indonesia are as follows: First, the results of this study indicate that there is plenty of room to improve the knowledge of Indonesian educated respondents on COVID-19. In turn, they can be opinion leaders and help their local government's programs in slowing

down the spread of the virus (e.g., through social distancing). Meanwhile, lack of transparency and poor communication about COVID-19 to the public may motivate hoarding or stockpiling of basic needs. Second, the tendency to engage in anticipatory purchase was modest to high among the respondents; hence, the government must also address their messages (e.g., do not panic) to the educated segment. Several strategies, such as ensuring the availability of product substitutions and price containment strategy for specific products, such as medical masks, can be implemented. Third, retailers can come up with products and substitutes that amplify consumers' sense of personal control and security during the pandemic. Similarly, manufacturing companies may contribute during the pandemic by coming up with products that can symbolically compensate for consumers' lack of personal control and security.

Several limitations of our study are as follows: First, our respondents are Indonesian professors; hence, the results of this study cannot be generalized to all Indonesians. Second, we are aware that social desirability bias might present in our study, especially in the CIHI scale. Social desirability bias occurs when respondents choose socially desirable or morally right responses which is not true to their actual feelings (Grimm, 2010). Nevertheless, we wish to highlight that to our best knowledge, this is the first study that discusses hoarding intention during the pandemic (a proxy of "panic buying") among the educated segment amid the COVID-19 pandemic. Future studies should also address regular citizens (e.g., housewife, blue-collar workers, entrepreneurs). Finally, in this study, we adapted only one dimension of HLOC which is associated with "chance," "luck," or some other external forces (e.g., God). Future studies may incorporate and demonstrate all dimensions of LOC (internal vs. external).

## Conclusion

Panic buying, which typically manifests as hoarding of basic needs during a disaster or a pandemic, can result in scarcity and price increases. Indonesia, the fourth world's largest country by population and a member of G-20, is not spared from panic buying amid the COVID-19 pandemic. This study framed this phenomenon in the context of educators. This study successfully gathered 265 university professors

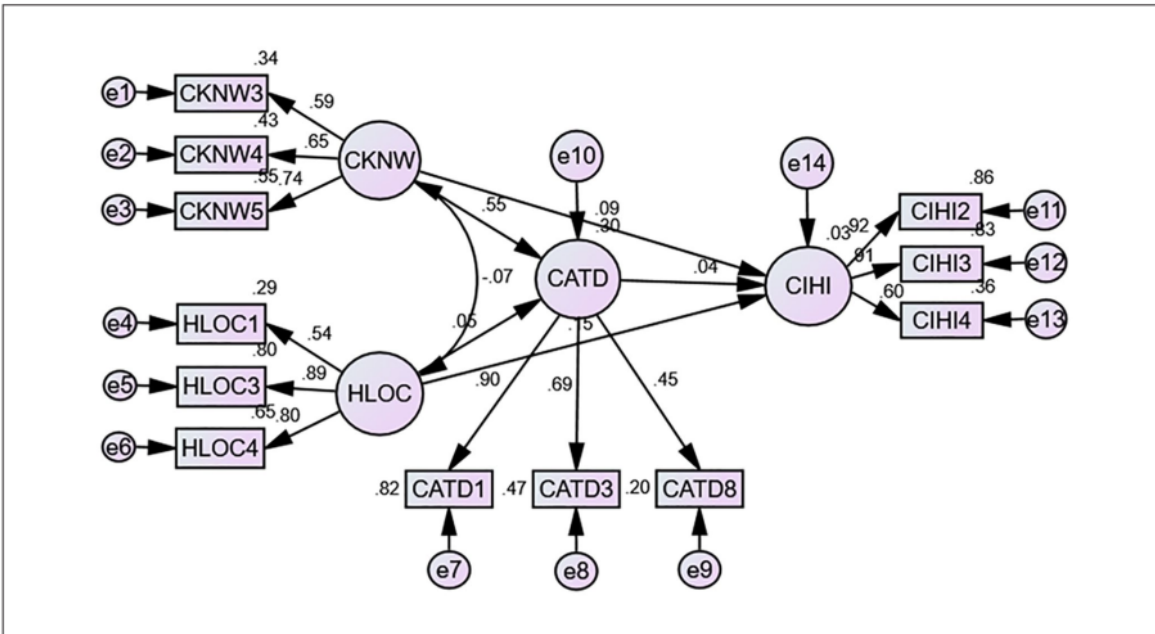

**Figure 6.** SEM model.  
 Note. SEM = structural equation modeling; CKNW = COVID-19-related knowledge; HLOC = health locus of control; CATD = COVID-19-related attitude; CIHI = COVID-19-induced hoarding intention.

**Table 4.** Goodness of Fit.

Indicators	Recommended thresholds	Results	Notes
RMSEA	<0.07	0.040	Good fit
SRMR	<0.08	0.060	Good fit
GFI	>0.95	0.960	Good fit
AGFI	>0.95	0.935	Moderate fit
NFI	>0.95	0.905	Moderate fit
TLI	>0.95	0.958	Good fit
CFI	>0.95	0.969	Good fit

Note. RMSEA = root mean square error of approximation; SRMR = standardized root mean square residual; GFI = goodness of fit index; AGFI = adjusted goodness of fit index; NFI = normed fit index; TLI = Tucker–Lewis index; CFI = comparative fit index.

**Table 5.** Regression Weights.

			Estimate	SE	CR	p
CATD	←	CKNW	.383	.068	5.658	***
CATD	←	HLOC	.021	.022	0.958	.338
CIHI	←	CATD	.136	.291	0.467	.641
CIHI	←	CKNW	.237	.224	1.058	.290
CIHI	←	HLOC	.232	.109	2.132	.033

Note. CATD = COVID-19-related attitude; CKNW = COVID-19-related knowledge; HLOC = health locus of control; CIHI = COVID-19-induced hoarding intention; CR = Composite Reliability; \*\*\* = P (sig.) < 0.001.

from 25 prominent public and private universities in Indonesia. Our study reveals that a better knowledge on COVID-19 pandemic increases vigilance toward the COVID-19 pandemic. Our study also reveals that external HLOC increases the intention to engage in hoarding or stockpiling of basic needs during the pandemic. Even though

we hesitate to conclude that the educated segment engaged in “panic buying,” the results of our study suggest that the respondents have the intentions to increase the amount of basic needs purchased during the COVID-19 outbreak in Indonesia. Moreover, what was often framed by the local media as “panic buying” might be a logical attempt to reduce the numbers of shopping activities during the pandemic to minimize the transmission risks and to anticipate potential shortage of basic needs.

## Appendix

### Respondent Profile.

	Numbers	%
Gender		
Male	135	50.9
Female	130	49.1
Age		
25–30	16	6
31–44	85	32.1
45–65	156	58.9
>65	8	3
Types of Higher Education (HE)		
Public university	26	90.2
Private university	239	9.8
Academic position		
Assistant professor	105	39.6
Associate professor	60	22.6
Full professor	7	2.6
Others	93	35.1
Teaching experience		
<2 years	12	4.5
3–10 years	83	31.3
>10 years	170	64.2

10

### Declaration of Conflicting Interests

The author(s) declared no potential conflicts of interest with respect to the research, authorship, and/or publication of this article.

### Funding

The author(s) received no financial support for the research and/or authorship of this article.

### ORCID iD

Jhanghiz Syahrivar  <https://orcid.org/0000-0002-4563-3413>

### References

- Abdollahi, M., Ghahramanian, A., Shahbazi, S., Rezaei, F., Naghili, B., & Asghari-Jafarabadi, M. (2019). *Developing a questionnaire to assess Iranian nurses' knowledge of and attitude to Middle East respiratory syndrome*. World Health Organization. [http://www.emro.who.int/images/stories/emhj/documents/in\\_press/developing\\_a\\_questionnaire\\_to\\_assess\\_iranian\\_nurses\\_knowledge\\_of\\_and\\_attitude\\_to\\_mers.pdf](http://www.emro.who.int/images/stories/emhj/documents/in_press/developing_a_questionnaire_to_assess_iranian_nurses_knowledge_of_and_attitude_to_mers.pdf)
- Abrams, E. M., & Greenhawt, M. (2020). Risk communication during COVID-19. *The Journal of Allergy and Clinical Immunology: In Practice*, 8(6), 1791–1794. <https://doi.org/10.1016/j.jaip.2020.04.012>
- Albarrak, A. I., Mohammed, R., Al Elayan, A., Al Fawaz, F., Al Masry, M., Al Shammari, M., & Miaygil, S. B. (2021). Middle East Respiratory Syndrome (MERS): Comparing the knowledge, attitude and practices of different health care workers. *Journal of Infection and Public Health*, 14, 89–96. <https://doi.org/10.1016/j.jiph.2019.06.029>

- Arafat, S. Y., Kar, S. K., Marthoenis, M., Sharma, P., Apu, E. H., & Kabir, R. (2020). Psychological underpinning of panic buying during pandemic (COVID-19). *Psychiatry Research*, 289, 113061. <https://doi.org/10.1016/j.psychres.2020.113061>
- Bacon, A. M., & Corr, P. J. (2020). Coronavirus (COVID-19) in the United Kingdom: A personality-based perspective on concerns and intention to self-isolate. *British Journal of Health Psychology*, 25(4), 839–848. <https://doi.org/10.1111/bjhp.12423>
- Bellini, A., Zanchi, C., Martelossi, S., Di Leo, G., Not, T., & Ventura, A. (2011). Compliance with the gluten-free diet: The role of locus of control in celiac disease. *The Journal of Pediatrics*, 158(3), 463–466. <https://doi.org/10.1016/j.jpeds.2010.08.034>
- Bhagavathula, A., Aldhaleei, W. A., Rahmani, J. R., Mahabadi, M. A., & Bandari, D. K. (2020). Novel Coronavirus (COVID-19) knowledge and perceptions: A survey of healthcare workers. *JMIR Public Health and Surveillance*, 6(2), e19160. <https://doi.org/10.2196/19160>
- Brown, A. J., Thaker, P. H., Sun, C. C., Urbauer, D. L., Bruera, E., Bodurka, D. C., & Ramondetta, L. M. (2017). Nothing left to chance? The impact of locus of control on physical and mental quality of life in terminal cancer patients. *Supportive Care in Cancer*, 25(6), 1985–1991. <https://doi.org/10.1007/s00520-017-3605-z>
- Brucks, M. (1985). The effects of product class knowledge on information search behavior. *Journal of Consumer Research*, 12(1), 1–16. <https://doi.org/10.1086/209031>
- Chairy, C., & Syahrivar, J. (2020). You reap what you sow: The role of karma in green purchase. *Cogent Business & Management*, 7(1), 1798066. <https://doi.org/10.1080/23311975.2020.1798066>
- Chan, E., Sengupta, J., & Mukhopadhyay, A. (2013). The antecedents of anticipatory purchase: Reconciling the two routes to optimism. *Journal of Consumer Psychology*, 23(1), 90–105. <https://doi.org/10.1016/j.jcps.2012.04.003>
- Clements, J. M. (2020). Knowledge and behaviors toward COVID-19 among U.S. residents during the early days of the pandemic: Cross-Sectional Online Questionnaire. *JMIR Public Health and Surveillance*, 6(2), e19161. <https://doi.org/10.2196/19161>
- Columbus, S. (2020, March 24). Who hoards? Honesty-humility and behavioural responses to the 2019/20 coronavirus pandemic. *PsyArXiv Preprints*. <https://doi.org/10.31234/osf.io/8e62v>
- Cukier, W., & Eagen, S. A. (2018). Gun violence. *Current Opinion in Psychology*, 19, 109–112. <https://doi.org/10.1016/j.copsyc.2017.04.008>
- De Salazar, P. M., Niehus, R., Taylor, A., Buckee, C. O., & Lipsitch, M. (2020). Using predicted imports of 2019-nCoV cases to determine locations that may not be identifying all imported cases. *Digital Access to Scholarship at Harvard (DASH)*. <http://nrs.harvard.edu/urn-3:HUL.InstRepos:42639518>
- Dubey, S., Biswas, P., Ghosh, R., Chatterjee, S., Dubey, M. J., Chatterjee, S., . . . Lavie, C. J. (2020). Psychosocial impact of COVID-19. *Diabetes and Metabolic Syndrome: Clinical Research and Reviews*, 14(5), 779–788. <https://doi.org/10.1016/j.dsx.2020.05.035>
- Elrggal, M. E., Karami, N. A., Rafea, B., Alahmadi, L., Al Shehri, A., Alamoudi, R., . . . Cheema, E. (2018). Evaluation of preparedness of healthcare student volunteers against Middle East

- respiratory syndrome coronavirus (MERS-CoV) in Makkah, Saudi Arabia: A cross-sectional study. *Journal of Public Health*, 26(6), 607–612. <https://doi.org/10.1007/s10389-018-0917-5>
- Frost, R. O., Hartl, T. L., Christian, R., & Williams, N. (1995). The value of possessions in compulsive hoarding: Patterns of use and attachment. *Behaviour Research and Therapy*, 33(8), 897–902. [https://doi.org/10.1016/0005-7967\(95\)00043-W](https://doi.org/10.1016/0005-7967(95)00043-W)
- Frost, R. O., & Steketee, G. (1998). Hoarding: Clinical aspects and treatment strategies. In M. A. Jenike, L. Baer, & W. E. Minichiello (Eds.), *Obsessive compulsive disorders: Practical management* (pp. 533–554). Mosby.
- Garbe, L., Rau, R., & Toppe, T. (2020). Influence of perceived threat of Covid-19 and HEXACO personality traits on toilet paper stockpiling. *PLOS ONE*, 15(6), Article e0234232. <https://doi.org/10.1371/journal.pone.0234232>
- Genoveva, G., & Syahrivar, J. (2020). Green lifestyle among Indonesian millennials: A comparative study between Asia and Europe. *Journal of Environmental Accounting and Management*, 8(4), 397–413. <https://doi.org/10.5890/JEAM.2020.12.007>
- Grimm, P. (2010). Social desirability bias. In *Wiley international encyclopedia of marketing*. <https://doi.org/10.1002/9781444316568.wiem02057>
- Hair, J. F., Black, W. C., Babin, B. J., Anderson, R. E., & Tatham, R. L. (2006). *Multivariate data analysis*. Pearson Prentice Hall.
- Jiang, F., Deng, L., Zhang, L., Cai, Y., Cheung, C. W., & Xia, Z. (2020). Review of the clinical characteristics of coronavirus disease 2019 (COVID-19). *Journal of General Internal Medicine*, 35(5), 1545–1549. <https://doi.org/10.1007/s11606-020-05762-w>
- Jones, B. D., Woodman, T., Barlow, M., & Roberts, R. (2017). The darker side of personality: Narcissism predicts moral disengagement and antisocial behavior in sport. *The Sport Psychologist*, 31(2), 109–116. <https://doi.org/10.1123/tsp.2016-0007>
- Jovančević, A., & Miličević, N. (2020). Optimism-pessimism, conspiracy theories and general trust as factors contributing to COVID-19 related behavior—A cross-cultural study. *Personality and Individual Differences*, 167, 110216. <https://doi.org/10.1016/j.paid.2020.110216>
- Kaiser, H. F. (1970). A second generation little jiffy. *Psychometrika*, 35(4), 401–415. <https://doi.org/10.1007/BF02291817>
- Kaiser, H. F. (1974). An index of factorial simplicity. *Psychometrika*, 39(1), 31–36. <https://doi.org/10.1007/BF02291575>
- Kim, J., Giroux, M., Gonzalez-Jimenez, H., Jang, S., Kim, S., Park, J., . . . Choi, Y. K. (2020). Nudging to reduce the perceived threat of Coronavirus and stockpiling intention. *Journal of Advertising*, 49, 633–647. <https://doi.org/10.1080/00913367.2020.1806154>
- Kirk, C. P., & Rifkin, L. S. (2020). I'll trade you diamonds for toilet paper: Consumer reacting, coping and adapting behaviors in the COVID-19 pandemic. *Journal of Business Research*, 117, 124–131. <https://doi.org/10.1016/j.jbusres.2020.05.028>
- Kulemeka, O. (2010). US consumers and disaster: Observing “panic buying” during the winter storm and hurricane seasons. *ACR North American Advances*, 37, 837–838.
- Lee, J. J., Kang, K. A., Wang, M. P., Zhao, S. Z., Wong, J. Y. H., O'Connor, S., . . . Shin, S. (2020). Associations between COVID-19 misinformation exposure and belief with COVID-19 knowledge and preventive behaviors: Cross-sectional online study. *Journal of Medical Internet Research*, 22(11), e22205. <https://doi.org/10.2196/22205>
- Lee, S., Hwang, C., & Moon, M. J. (2020). Policy learning and crisis policy-making: Quadruple-loop learning and COVID-19 responses in South Korea. *Policy and Society*, 39(3), 363–381. <https://doi.org/10.1080/14494035.2020.1785195>
- Lin, C. A., Xu, X., & Dam, L. (2021). Information source dependence, presumed media influence, risk knowledge, and vaccination intention. *Atlantic Journal of Communication*, 29, 53–64. <https://doi.org/10.1080/15456870.2020.1720022>
- Naeem, M. (2020). Do social media platforms develop consumer panic buying during the fear of Covid-19 pandemic. *Journal of Retailing and Consumer Services*, 58, 102226. <https://doi.org/10.1016/j.jretconser.2020.102226>
- Newbold, K. B., Heddle, N. M., Lane, S. J., Arnold, E., Eyles, J., & Webert, K. (2014). Risks, benefits and the role of stakeholders in pathogen reduction technology. *Health, Risk & Society*, 16(6), 547–564. <https://doi.org/10.1080/13698575.2014.943159>
- Norman, P., Bennett, P., Smith, C., & Murphy, S. (1998). Health locus of control and health behaviour. *Journal of Health Psychology*, 3(2), 171–180. <https://doi.org/10.1177/135910539800300202>
- Pantano, E., Pizzi, G., Scarpi, D., & Dennis, C. (2020). Competing during a pandemic? Retailers' ups and downs during the COVID-19 outbreak. *Journal of Business Research*, 116, 209–213. <https://doi.org/10.1016/j.jbusres.2020.05.036>
- Poushter, J., & Fetterolf, J. (2019, April 22). How people around the world view religion's role in their countries. *Pew Research Center*. <https://www.pewresearch.org/global/2019/04/22/how-people-around-the-world-view-religions-role-in-their-countries/>
- Quarantelli, E. L. (1993). Community crises: An exploratory comparison of the characteristics and consequences of disasters and riots. *Journal of Contingencies and Crisis Management*, 1(2), 67–78. <https://doi.org/10.1111/j.1468-5973.1993.tb00009.x>
- Rajkumar, R. P. (2020). COVID-19 and mental health: A review of the existing literature. *Asian Journal of Psychiatry*, 52, 102066. <https://doi.org/10.1016/j.ajp.2020.102066>
- Rayda, N. (2020, March 3). President Jokowi urges calm amid signs of panic buying after Indonesia's first COVID-19 cases. *Channelnewsasia.com*. <https://www.channelnewsasia.com/news/asia/covid-19-indonesia-jokowi-panic-buying-12495306>
- Rimal, R. N., & Real, K. (2003). Perceived risk and efficacy beliefs as motivators of change: Use of the risk perception attitude (RPA) framework to understand health behaviors. *Human Communication Research*, 29(3), 370–399. <https://doi.org/10.1111/j.1468-2958.2003.tb00844.x>
- Rotter, J. B. (1982). *The development and applications of social learning theory: Selected papers*. Praeger.
- Rucker, D. D., & Galinsky, A. D. (2008). Desire to acquire: Powerlessness and compensatory consumption. *Journal of Consumer Research*, 35(2), 257–267. <https://doi.org/10.1086/588569>
- Schreiber, J. B., Nora, A., Stage, F. K., Barlow, E. A., & King, J. (2006). Reporting structural equation modeling and confirmatory factor analysis results: A review. *The Journal of Educational Research*, 99(6), 323–338. <https://doi.org/10.3200/JOER.99.6.323-338>
- Schreitmüller, J., & Loerbroks, A. (2020). The role of self-efficacy and locus of control in asthma-related needs and outcomes:

- A cross-sectional study. *Journal of Asthma*, 57(2), 196–204. <https://doi.org/10.1080/02770903.2018.1556687>
- Sheu, J. B., & Kuo, H. T. (2020). Dual speculative hoarding: A wholesaler-retailer channel behavioral phenomenon behind potential natural hazard threats. *International Journal of Disaster Risk Reduction*, 44, 101430. <https://doi.org/10.1016/j.ijdrr.2019.101430>
- Syahrivar, J., & Pratiwi, R. S. (2018). A correlational study of religiosity, guilt, and compensatory consumption in the purchase of halal products and services in Indonesia. *Advanced Science Letters*, 24(10), 7147–7151. <https://doi.org/10.1166/asl.2018.12428>
- Szymkowiak, A., Kulawik, P., Jeganathan, K., & Guzik, P. (2020). *In-store epidemic behavior: Scale development and validation* (ArXiv Preprint ArXiv:2005.02764). <https://arxiv.org/abs/2005.02764>
- Tassiello, V., & Tillotson, J. S. (2020). How subjective knowledge influences intention to travel. *Annals of Tourism Research*, 80, 102851. <https://doi.org/10.1016/j.annals.2019.102851>
- Temsah, M. H., Alhuzaimi, A. N., Alamro, N., Alrabiaah, A., Al-Sohime, F., Alhasan, K., . . . Jamal, A. (2020). Knowledge, attitudes and practices of healthcare workers during the early COVID-19 pandemic in a main, academic tertiary care centre in Saudi Arabia. *Epidemiology and Infection*, 148, e203.
- Triberti, S., Drosini, I., & Pravettoni, G. (2021). Social distancing is the right thing to do: Dark Triad behavioral correlates in the COVID-19 quarantine. *Personality and Individual Differences*, 170, 110453. <https://doi.org/10.1016/j.paid.2020.110453>
- 12 Tsao, Y. C., Raj, P. V. R. P., & Yu, V. (2019). Product substitution in different weights and brands considering customer segmentation and panic buying behavior. *Industrial Marketing Management*, 77, 209–220. <https://doi.org/10.1016/j.indmarman.2018.09.004>
- Van Bavel, J. J., Boggio, P., Capraro, V., Cichocka, A., Cikara, M., Crockett, M., . . . Ellemers, N. (2020). Using social and behavioural science to support COVID-19 pandemic response. *Nature Human Behaviour*, 4, 460–471. <https://doi.org/10.1038/s41562-020-0884-z>
- van Geel, M., Goemans, A., Toprak, F., & Vedder, P. (2017). Which personality traits are related to traditional bullying and cyberbullying? A study with the Big Five, Dark Triad and sadism. *Personality and Individual Differences*, 106, 231–235. <https://doi.org/10.1016/j.paid.2016.10.063>
- Wallston, K. A., Wallston, B. S., & DeVellis, R. (1978). Development of the multidimensional health locus of control (MHLC) scales. *Health Education Monographs*, 6(1), 160–170. <https://doi.org/10.1177/109019817800600107>
- Wilkie, W. L., & Weinreich, R. P. (1972). Effects of the number and type of attributes included in an attitude model: More is not better. In *Proceedings of the Third Annual Conference of the Association for Consumer Research* (pp. 325–340). <https://www.acrwebsite.org/volumes/12010/volumes/sv02/SV-02>
- Wilski, M., Kocur, P., Broła, W., & Tasiemski, T. (2020). Psychological factors associated with self-management in multiple sclerosis. *Acta Neurologica Scandinavica*, 142, 50–57. <https://doi.org/10.1111/ane.13236>
- Wirz, C. D., Mayorga, M., & Johnson, B. B. (2020). A longitudinal analysis of Americans' media sources, risk perceptions, and judged need for action during the Zika outbreak. *Health Communication*, 1–10. <https://doi.org/10.1080/10410236.2020.1773707>
- Yulisman, L. (2020, March 2). Mother and daughter test positive for coronavirus in Indonesia, first confirmed cases in the country. *The Straits Times*. <https://www.straitstimes.com/asia/se-asia/indonesia-confirms-two-coronavirus-cases-president>
- 13 Zettler, I., Schild, C., Lilleholt, L., Kroencke, L., Utesch, T., Moshagen, M., & Geukes, K. (2020, March 23). The role of personality in COVID-19 related perceptions, evaluations, and behaviors: Findings across five samples, nine traits, and 17 criteria. *PsyArXiv Preprints*. <https://doi.org/10.31234/osf.io/pkm2a>
- Zheng, R., Shou, B., & Yang, J. (2021). Supply disruption management under consumer panic buying and social learning effects. *Omega*, 101, 102238. <https://doi.org/10.1016/j.omega.2020.102238>

# COVID-19-Induced Hoarding Intention Among the Educated Segment in Indonesia

## ORIGINALITY REPORT

13%

SIMILARITY INDEX

13%

INTERNET SOURCES

11%

PUBLICATIONS

13%

STUDENT PAPERS

## PRIMARY SOURCES

1	<a href="http://primenjena.psihologija.ff.uns.ac.rs">primenjena.psihologija.ff.uns.ac.rs</a> Internet Source	1%
2	Submitted to Sim University Student Paper	1%
3	<a href="http://repo.uum.edu.my">repo.uum.edu.my</a> Internet Source	1%
4	<a href="http://eprints.undip.ac.id">eprints.undip.ac.id</a> Internet Source	1%
5	Chairy Chairy, Jhanghiz Syahrivar. "You reap what you sow: The role of Karma in Green purchase", Cogent Business & Management, 2020 Publication	1%
6	<a href="http://www.researchsquare.com">www.researchsquare.com</a> Internet Source	1%
7	Submitted to Macquarie University Student Paper	1%

8	Tingting Li, He Bu, Wenjie Duan. "A brief measure of perceived courtesy and affiliate stigma on COVID-19: A study with a sample from China", Personality and Individual Differences, 2021 Publication	1 %
9	<a href="http://journal.seisense.com">journal.seisense.com</a> Internet Source	1 %
10	<a href="http://journals.sagepub.com">journals.sagepub.com</a> Internet Source	1 %
11	Wai Yen Tang, Felix Reer, Thorsten Quandt. "The interplay of gaming disorder, gaming motivations, and the dark triad", Journal of Behavioral Addictions, 2020 Publication	1 %
12	Submitted to Navitas Professional Institute Pty Ltd Student Paper	1 %
13	Submitted to University of Bradford Student Paper	1 %
14	<a href="http://agba.us">agba.us</a> Internet Source	1 %
15	Submitted to King's College Student Paper	1 %
16	Submitted to Lincoln University Student Paper	1 %



17 Submitted to Chester College of Higher Education 1 %  
Student Paper

---

18 Submitted to University of Western Sydney 1 %  
Student Paper

---

19 businessperspectives.org 1 %  
Internet Source

---

20 Submitted to University of Hong Kong 1 %  
Student Paper

---

21 jurnal.unimus.ac.id 1 %  
Internet Source

---

22 uir.unisa.ac.za 1 %  
Internet Source

---

Exclude quotes Off

Exclude matches < 1%

Exclude bibliography Off

# COVID-19-Induced Hoarding Intention Among the Educated Segment in Indonesia

---

GRADEMARK REPORT

---

FINAL GRADE

**/0**

GENERAL COMMENTS

**Instructor**

---

PAGE 1

---

PAGE 2

---

PAGE 3

---

PAGE 4

---

PAGE 5

---

PAGE 6

---

PAGE 7

---

PAGE 8

---

PAGE 9

---

PAGE 10

---

PAGE 11

---

PAGE 12

---

PAGE 13

---